

## 2.0A Single-Phase GLass Passivated Bridge Rectifiers

Recifier Reverse Voltage 50V to 1000V



### DFM

### Features

- Glass passivated junctor
- The plastic material used carries Underwriters Laboratory flammability recognition 94V-0
- Suge overload ratings to 50 amperes peak
- Ideal for printed circuit board application
- High temperature soldering guaranteed 265°C/10 seconds at 5 lbs(2.3kg)tension

### Mechanical Data

Case:Molded plastic

Terminals:Platde leads solderable per MIL-STD-750, Method 2026

Polarity:Polarity symbols molded or Marked on body

Mounting Position:Any

Weight:0.011 ounce,0.32 grams(approx)

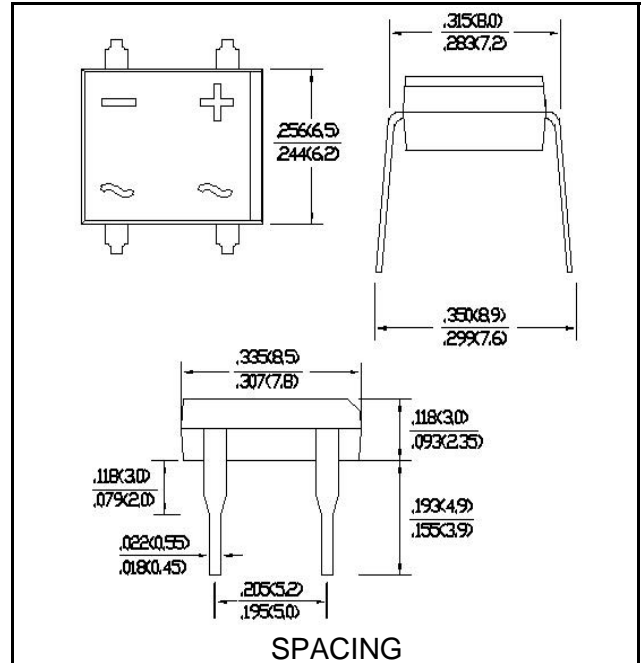

### Maximum Ratings & Thermal Characteristics

Rating at 25°C ambient temperature unless otherwise specified,Resistive or inductive load,60HZ.

For Capacitive load derate current by 20%

Parameter	Symbol	DF2005M	DF201M	DF202M	DF204M	DF206M	DF208M	DF210M	unit
Maximum repetitive peak reverse voltage	VRRM	50	100	200	400	600	800	1000	V
Maximum RMS bridge input voltage	VRMS	35	70	140	280	420	560	700	V
Maximum DC blocking voltage	VDC	50	100	200	400	600	800	1000	V
Maximum average forward rectified output current at TA=40°C	IF(AV)	2.0							A
Peak forward surge current single sine-wave superimposed on rated load (JEDEC Method)	IFSM	60							A
Rating for fusing(t<8.3ms)	I <sup>2</sup> t	10							A <sup>2</sup> sec
Typical thermal resistance per element(1)	ReJA	110							°C/w
Typical thermal resistance per element(2)	Cj	25.0							PF
Operating junction and stroage temperature range	TJ, TSTG	-55to+150							°C

### Electrical Characteristics

Rating at 25°C ambient temperature unless otherwise specified,Resistive or inductive load,60HZ.

For Capacitive load derate current by 20%

Parameter	Symbol	DF2005M	DF201M	DF202M	DF204M	DF206M	DF208M	DF210M	unit
Maximum instantaneous forward voltage drop per leg at 2.0A	VF	1.1							V
Maximum DC reverse current at ratde TA=25°C	IR	10							UA
DC blocking voltage per element TA=125°C		500							

Notes:(1)Thermal resistance from Junction to Ambemt on P.C.board mounting.

(2)Measured at 1.0MHz and applied reverse voltage of 4.0 volts.

## Rating and Characteristic Curves (TA=25°C Unless otherwise noted)

FIG.1-DERATING CURVE FOR

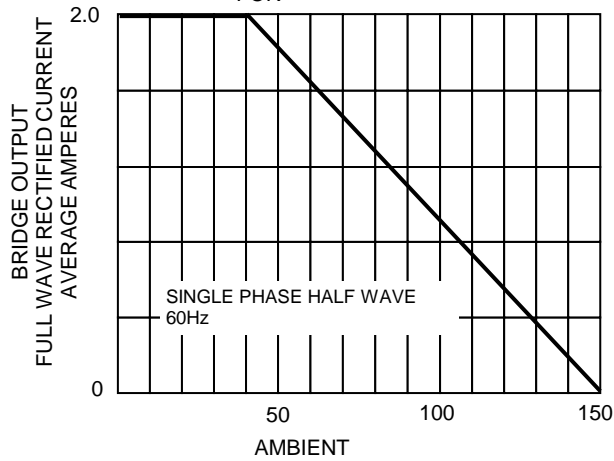

FIG.2-MAXIMUM NON-REPETITIVE SURGE CURRENT

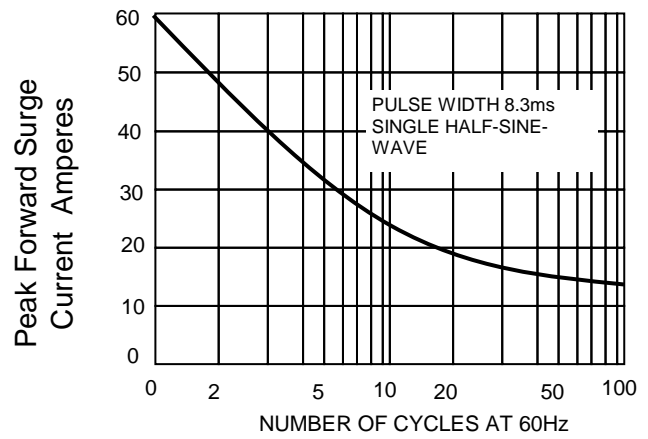

FIG.3-TYPICAL JUNCTION

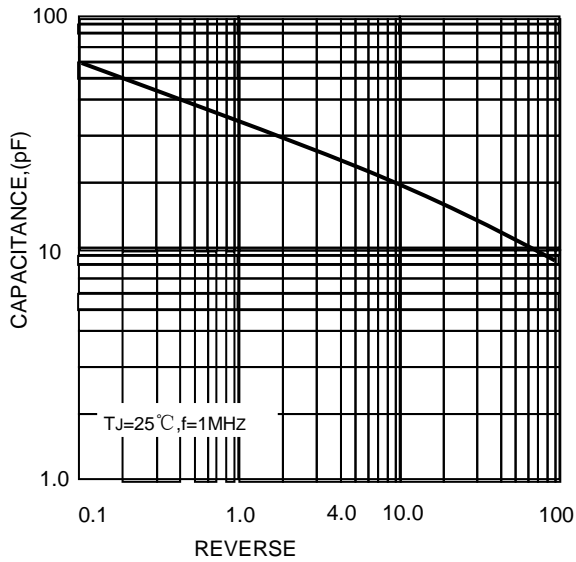

FIG.4-TYPICAL FORWARD CHARACTERISTICS

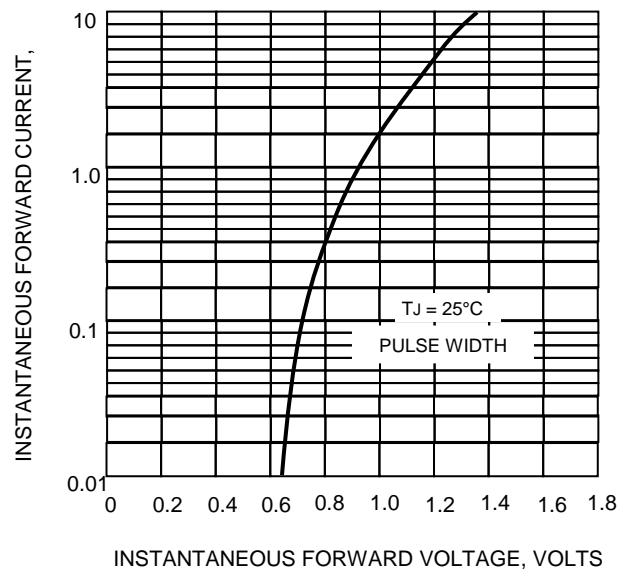

FIG.5-TYPICAL REVERSE

